



**Operation Manual of
Outdoor High-Speed Pan/Tilt
(with Infrared Lighting)**

V 1.4

Please read the operation manual carefully before using the unit.

SAFETY PRECAUTIONS

	CAUTION RISK OF ELECTRIC SHOCK. DO NOT OPEN!	
CAUTION: TO REDUCE THE RISK OF ELECTRICAL SHOCK, DO NOT OPEN COVERS. NO USER SERVICEABLE PARTS INSIDE. REFER SERVICING TO QUALIFIED SERVICE PERSONNEL.		



The lightning flash with a arrowhead symbol, in an equilateral triangle, is intended to alert the user. There is uninsulated “dangerous voltage” presence near by the product’s enclosure which may be risk of to persons.



The exclamation point within an equilateral triangle is intended to alert the user to reference of the important operating and maintenance (servicing) instructions .

THE PRODUCT CODE MARKED ON THE BOTTOM COVER. PLEASE FILL THE CODE IN THE FOLLOWING BLANK .PLEASE SAVING THIS SPECIFICATION CAREFULLY, SO THAT CHECKING

MODEL: _____
PRODUCT CODE: _____

INDEX

I	Important Safeguards.....	1
II	Introduction of Functions	2
III	The Installation of the System	3
	1. Modify the Protocol and the Address	3
	2. RS485 Terminal Resistor	5
	3. Sizes	6
	4. Wall Mounting	6
	5. Base Plate Mounting	9
	6. Connection	10
IV	Setup of the Menu of the Dome Camera	12
	1. Basic Operation of the Menu	12
	2. Setup of the Menu	12
	3. Appendix to the Menu	14
V	Special Operation	16
VI	Technical Data	17

I IMPORTANT SAFEGUARDS

1. Please read the operation manual carefully before installing and operating the units.
2. Power Supply: 220V/110V/24V, refer to the sticker on the product.
3. During the course of transportation, storage and installation, the product should be avoided from incorrect operation such as heavy pressing, strong vibration etc., which can cause damage of product as there are sophisticated optical and electronic devices inside the machine.
4. Do not attempt to disassemble the camera. In order to prevent electric shock, do not remove screws or covers. There are no user-serviceable parts inside.
5. Always follow all electric standards for safety when it is in operation. Adopt the particular power supply which is provided with the unit. RS-485 and video signal should keep enough distance with the high voltage equipments and cables when they are in transmission. Precautions for anti-lighting and anti-surgings should be taken if necessary.
6. Do not operate it, in case temperature, humidity and power supply are beyond the limited stipulations.
7. Do not let the camera aim at the sun or the object with extreme light whatsoever it is switched on or not. Do not let the camera aim at or to monitor bright and standstill for a long time.
8. Do not use aggressive detergent to clean the main body of the camera. Wipe dirt with dry cloth. If needed, mild detergent can be used suitably.
9. Operate the intelligent speed dome camera with great care to avoid shock or vibration .It operate incorrectly, the speed dome could be damaged.
10. Be careful to avoid crashing, never mount the unit on a ceiling that can not support its weight.
11. If necessary, use a commercial lens cleaning paper to clear the lens windows. Gently wipe the lens window until clean.

II Introduction of Functions

1. Turning 360 ° horizontally and continuously with unlimited positions and turning +33 °-70 ° vertically.
2. The horizontal speed is 0 - 40 %/sec while the vertical speed is 0 - 20 %/sec (wind speed is less than 50 miles/hour).
3. At the preset position, the horizontal speed is 0 - 100 %/sec while the vertical speed is 0 - 40 %/sec (wind speed is less than 50 miles/hour).
4. Automatic control of constant temperature, manual rain wiper/defroster control.
5. IP grade IP66.
6. The bearable maximum wind speed is 130 miles/hour.
7. 128 preset positions in memory and 6sets of programmable patrol, as well as linear scan between two points with adjustable speed and variable direction,
8. 16 common protocols are integrated, four kinds of baud rate 2400/4800/9600/19200 bps are available and 512 addresses are supported (0 - 512).
9. The Style Of IR PTZ has IR visual distance 120 meter.

III The Installation of the System

1. Modify the Protocol and the Address (jump over this section if no modification)

Take out the small metal cover on the bottom shown as dotted-lined part on Figure 3.1.1 to expose DIP switch of the address and the protocol shown as Figure 3.1.2. The detailed drawing is shown as in Figure 3.1.1.

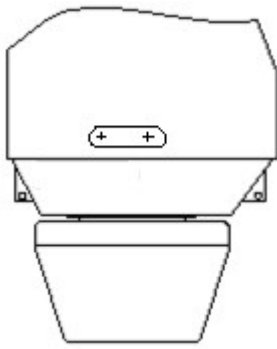

Figure 3.1.1

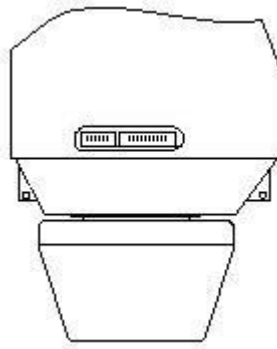

Figure 3.1.2

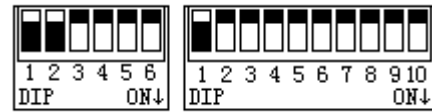

Figure 3.1.3

Shown as Figure 3.1.3, the 10-bit DIP 1 – 9bit stands for the addresses which can be from 0 to 512. the NO.10-bit DIP is the switch of the terminal resistor 120Ω , if NO.10-bit DIP is ON, then between Line A and Line B on 485 bus there is a terminal resistor 120Ω connected. The default setup is at OFF which means the terminal resistor is opened.

The 6-bit DIP stands for the protocols in which bits 1-4 mean the protocol while bits 5-6 means the baud rate. Push the DIP downward means ON otherwise it means OFF. For example the address in the figure means 1 while the protocol means PELCO-D with the baud rate of 2400bps which can be found from the table.

Address of PT	Status of DIP Switch									
	DIP-1	DIP-2	DIP-3	DIP-4	DIP-5	DIP-6	DIP-7	DIP-8	DIP-9	DIP-10
1	ON	OFF	OFF	OFF	OFF	OFF	OFF	OFF	OFF	OFF
2	OFF	ON	OFF	OFF	OFF	OFF	OFF	OFF	OFF	OFF
3	ON	ON	OFF	OFF	OFF	OFF	OFF	OFF	OFF	OFF
4	OFF	OFF	ON	OFF	OFF	OFF	OFF	OFF	OFF	OFF
5	ON	OFF	ON	OFF	OFF	OFF	OFF	OFF	OFF	OFF
6	OFF	ON	ON	OFF	OFF	OFF	OFF	OFF	OFF	OFF
7	ON	ON	ON	OFF	OFF	OFF	OFF	OFF	OFF	OFF
8	OFF	OFF	OFF	ON	OFF	OFF	OFF	OFF	OFF	OFF
9	ON	OFF	OFF	ON	OFF	OFF	OFF	OFF	OFF	OFF
10	OFF	ON	OFF	ON	OFF	OFF	OFF	OFF	OFF	OFF
11	ON	ON	OFF	ON	OFF	OFF	OFF	OFF	OFF	OFF
12	OFF	OFF	ON	ON	OFF	OFF	OFF	OFF	OFF	OFF
13	ON	OFF	ON	ON	OFF	OFF	OFF	OFF	OFF	OFF
14	OFF	ON	ON	ON	OFF	OFF	OFF	OFF	OFF	OFF
15	ON	ON	ON	ON	OFF	OFF	OFF	OFF	OFF	OFF
16	OFF	OFF	OFF	OFF	ON	OFF	OFF	OFF	OFF	OFF
17	ON	OFF	OFF	OFF	ON	OFF	OFF	OFF	OFF	OFF
18	OFF	ON	OFF	OFF	ON	OFF	OFF	OFF	OFF	OFF
...

Table 1 Table of Addresses in DIP Switch

Examples:

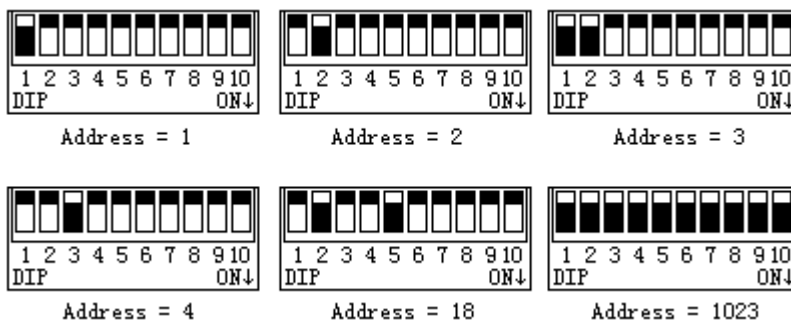

Type of Protocols	Selection of Communication Protocols				Common Baud Rates	
	DIP-1	DIP-2	DIP-3	DIP-4	DIP-5	DIP-6
SAMSUNG	ON	OFF	OFF	OFF	OFF	ON
B01	ON	OFF	OFF	OFF	OFF	ON
NEON	ON	OFF	OFF	OFF	OFF	ON
Santachi	OFF	ON	OFF	OFF	OFF	ON
PELCO-D	ON	ON	OFF	OFF	OFF	OFF
PELCO-P/4800	OFF	OFF	ON	OFF	ON	OFF
PELCO-P/9600					OFF	ON
PANASONIC	ON	OFF	ON	OFF	OFF	ON
Longcomity	OFF	ON	ON	OFF	OFF	ON
HUNDA600	ON	ON	ON	OFF	OFF	ON
LILIN	OFF	OFF	OFF	ON	OFF	ON
VICON	ON	OFF	OFF	ON	ON	OFF
MOLYNX	OFF	ON	OFF	ON	OFF	ON
KALATEL	ON	ON	OFF	ON	ON	OFF
VCL	OFF	OFF	ON	ON	OFF	ON
Reserved	ON	OFF	ON	ON	OFF	ON
ALEC	OFF	ON	ON	ON	OFF	ON
Ultrak	ON	ON	ON	ON	OFF	ON

Table 2 Table of Protocols in DIP Switch

Some protocols and their common baud rates in DIP switch are as follows:

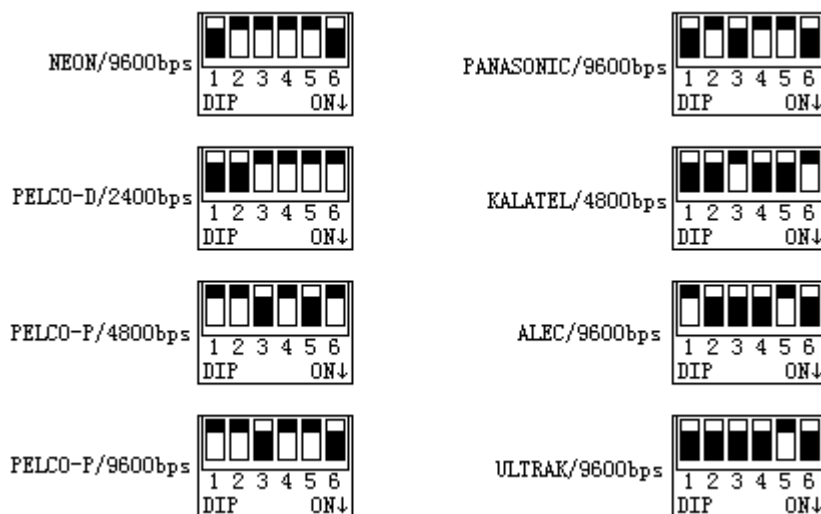

Baud Rates of Communication					Setup of Baud Rates	
	DIP-1	DIP-2	DIP-3	DIP-4	DIP-5	DIP-6
2400 bps	-	-	-	-	OFF	OFF
4800 bps	-	-	-	-	ON	OFF
9600 bps	-	-	-	-	OFF	ON
19200 bps	-	-	-	-	ON	ON

Table 3 Table of Baud Rates

3. Sizes

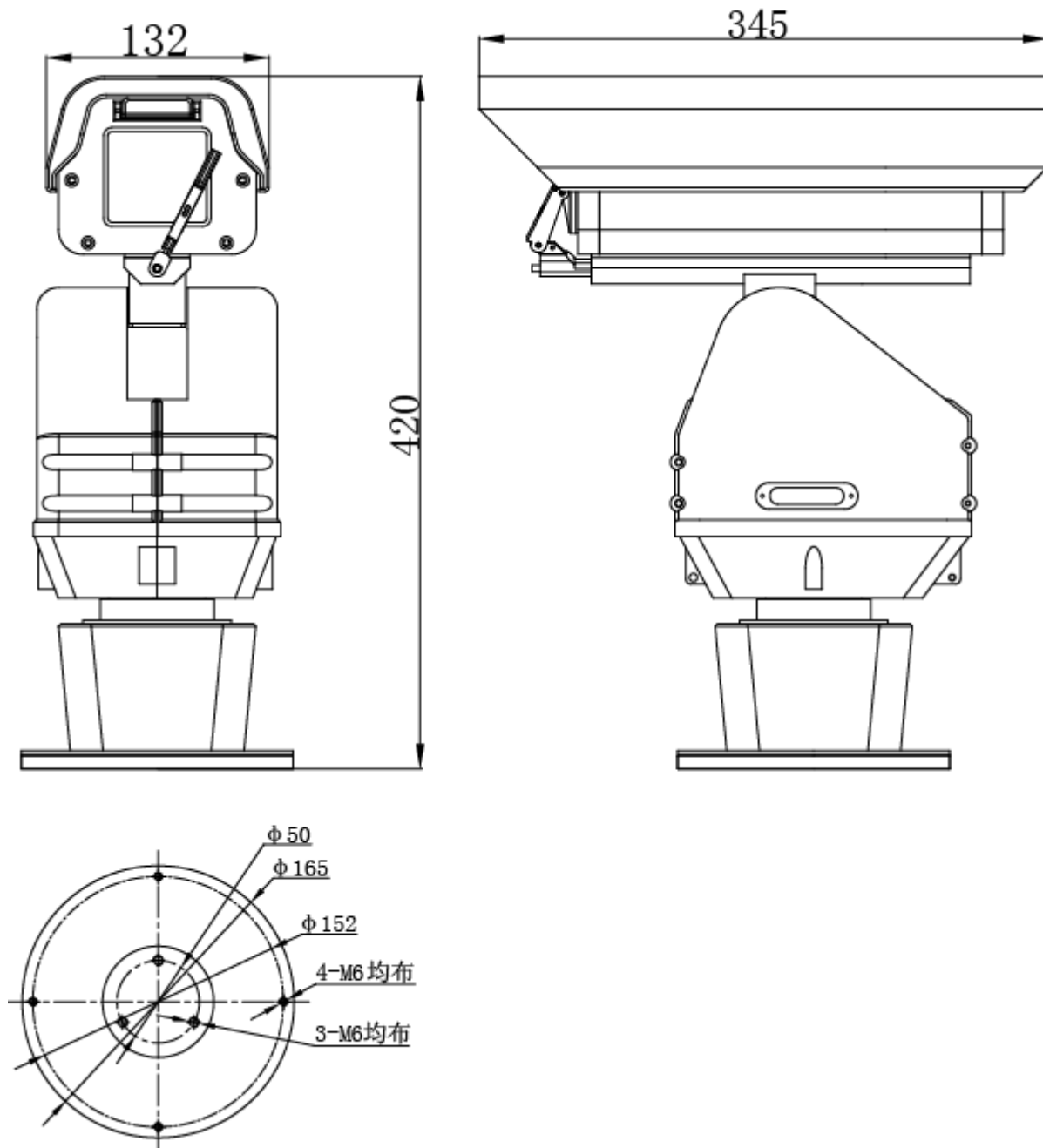

4. Wall Mounting

The first step is to mount the bracket on the wall which is shown as in Figure 3.4.1. Figure 3.4.2 is the drawing of sizes of mounting holes.

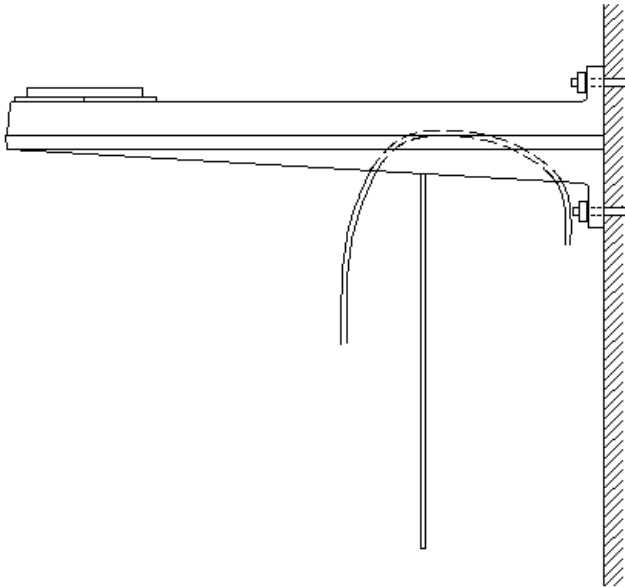

Figure 3.4.1

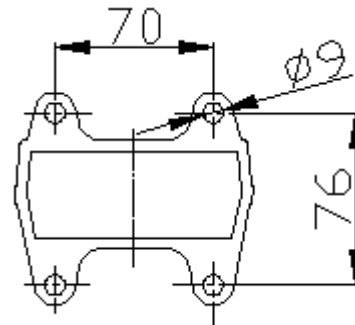

Figure 3.4.2

It is suggested to mount the support with M8 screw.

There is a mobile plate under the support. It can be laid down if screws on the front are taken off. Lead wires of the system into the support for connection.

The second step is to put the pan/tilt on the support and tighten screws upward beneath the support, shown as in Figure 3.4.3.

Please take M6 × 20 screw.

The third step is to connect output wires of the pan/tilt and the system, wrap the joints by insulation tape and fix the mobile plate under the support.

It should be like what Figure 3.4.4 shows.

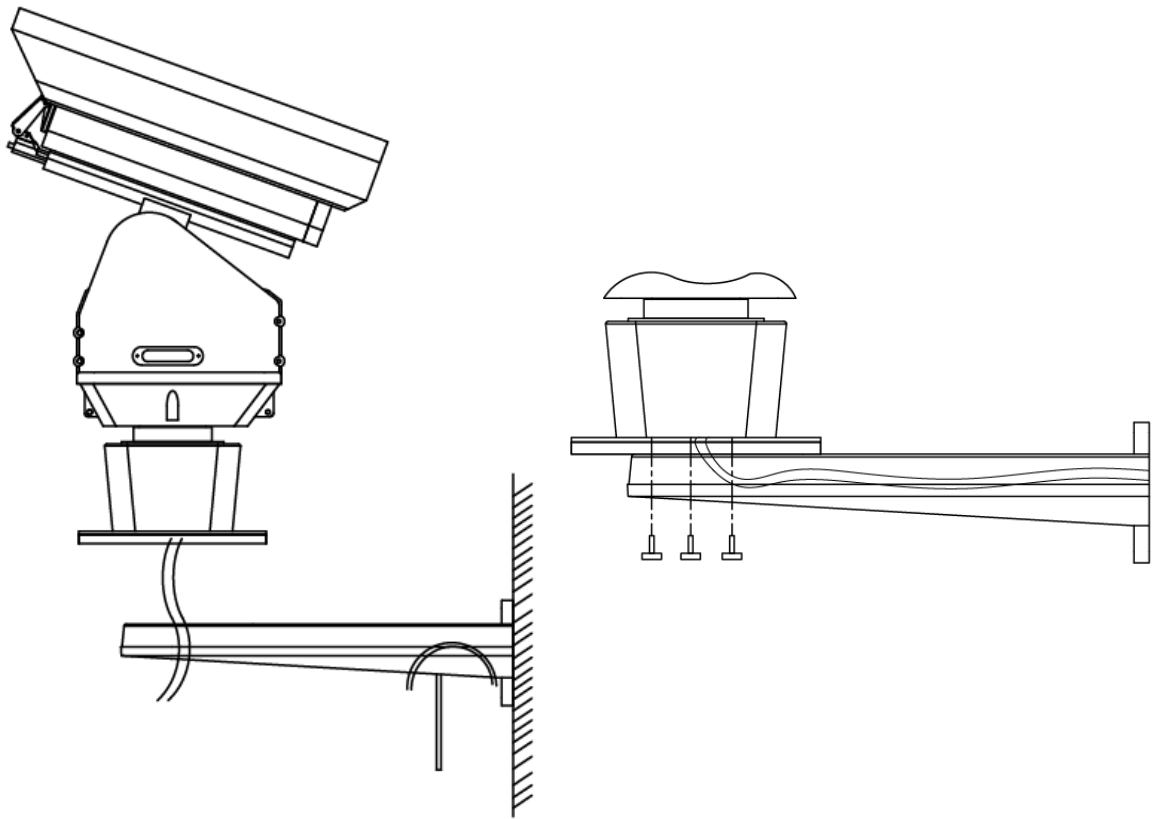

Figure 3.4.3

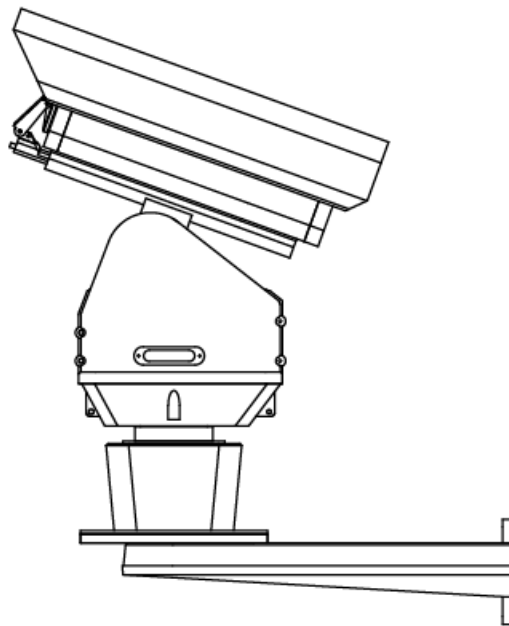
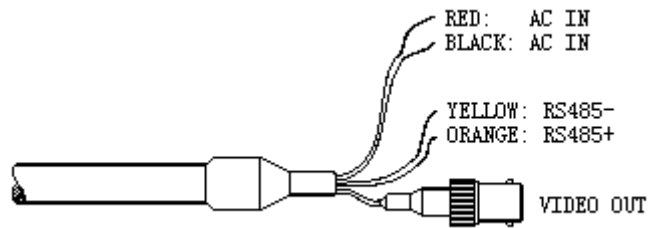

Figure 3.4.4

5. Connections

Please refer to the descriptions of following drawing.

- 1) System Wires



RED	Input of AC Power Supply
BLACK	Input of AC Power Supply
YELLOW	Control Wire RS485- (B)
ORANGE	Control Wire RS485+ (A)
VIDEO OUT	Video Output

2) Alarm Wires

Blue	Alarm Input 1
Green	Alarm Input 2
white	Alarm Common Terminal

- ⚠ The alarm input should be switch signal otherwise internal circuit shall be damaged.
- ⚠ The alarm shall be linked with the presser point, which should be set in the menu. In case two channels have alarm signals simultaneously, the pan/tilt shall response upon two channels one by one with the time interval of 2 seconds.
- ⚠ In case the alarm signal is inputted, the PT shall have no response upon functions such as “AUTO PAN”, “Patrol” and “Pattern” and so on.

IV Description of Functions of the Menu

1. Basic Operations on the Menu

Open the main menu by the control keyboard or the matrix via the instruction of “Call Preset 64”. In addition the main menu can be also opened by “Call Preset 1” twice within 4 seconds.

When the menu is displayed on the screen, operate “TILT UP”, “TILT DOWN” to move the cursor to the options to be set up, and operate “PAN LEFT”, “PAN RIGHT” to modify the content or the instruction to enter into this option.

The operation can be accelerated in case the joystick is pushed towards one direction for more than 1 second.

All setups of the menu shall not be lost even after power failure.

The application under special cases can be seen in the instruction of functions of the menu.

2. Setup of the Menu

2.1 Main Menu

DISPLAY SETUP: Enter into the submenu to setup display on the screen, such as ID DISPLAY, TITLE DISPLAY and CAMERA DISPLAY.

CAMERA SETUP: Enter into the submenu of normal data of the camera.

CONTROL SETUP: Enter into the submenu of the control data of the PT.

PROGRAM: Enter into the submenu to setup enhanced function of the PT.

CAM DEFAULT SET: Restore camera default settings.

RESET PT: Reset of the PT.

EXIT: Exit the main menu.

MAIN MENU	
1.	DISPLAY SETUP
2.	CAMERA SETUP
3.	CONTROL SETUP
4.	PROGRAM
5.	CAM DEFAULT SET
6.	RESET PT
7.	EXIT

2.2 Display Setup

ID DISPLAY: When this option is set at ON, the monitor shall display the address of the camera such as “CAM 001”.

ID POS: To set up the display location of the address, which can be displayed at TOP-L (top left), TOP-R (top right), BOTT-R (bottom right) and BOTT-L (bottom left).

TITLE DIS: when this option is set at ON, the title of the presets can be displayed on the left of the screen when the preset is called, such as “NO.001 ABCDEFGH”. If no title is set, then only “NO.001” is displayed. The modification of the title of the preset is set on the PROGRAM option.

TITLE POS: to set the display location of the title of the preset, which can be from Line 1 to Line 10. The Line 1 is on the top of the screen.

CAM DISPLAY: when this option is set at ON, the display screen of the camera can be displayed.

RETURN: to exit the main menu.

DISPLAY SETUP	
1.	ID DISPLAY ON
2.	ID POS TOP-L
3.	TITLE DIS ON
4.	TITLE POS 01 LINE
5.	CAM DISPLAY ON
6.	PT ANGLE
7.	LANGUAGE
8.	RETURN

Camera Setup

SLOW SHUTTER: Slow Shutter function with Man/Auto options.

When the option be AUTO, ASS shall be displayed on the monitor.

BACK LIGHT: Backlight Compensation ON/OFF.

ICR SHOT: Low Illumination, ON - open/AUTO - automatic.

IRIS: Automatic Exposure, AUTO - automatic/MANU - manual.

D-ZOOM: Digital Zoom, ON - open/OFF - close.

CAMERA SETUP	
1.	SLOWSHUTTER AUTO
2.	BACK LIGHT OFF
3.	ICR SHOT AUTO
4.	D-ZOOM ON
5.	IRIS AUTO
6.	WDR ON
7.	WB SET
8.	MENU OF CAM
9.	RETURN

FOCUS: Automatic focusing, AUTO - automatic/MANU - manual.

WB SET: White Balance, ATW /INDOOR /OUTDOOR /ONEPUSH /AUTO /MANU

MENU OF CAM: this option is empty.

RETURN: return to the main menu.

Control Setup

WIPER: rain wiper control.

DEFROSTER: defroster control.

RESERVED AUX: auxiliary switch control.

WIPE MODE: SERIES/ONE PUSH

ALARM CONTROL: please turn over

HOME OPTION: please turn over

SET NORTH:Reset the North location

CONTROL SETUP	
1. WIPER	ON
2. DEFOGGER	OFF
3. RESERVED AUX	N/A
4. WIPER MODE	SER
5. ALARM CONTROL	
6. HOME OPTION	
7. SET NORTH	
8. RETURN	

Alarm Setup

ALARM1: external alarm 1 control.

LINKAGE1: set linkage with external alarm 1.

ALARM2: external alarm 2 control.

LINKAGE2: set linkage with external alarm 2.

ALARM CONTROL	
1. ALARM 1	ON
2. LINKAGE1	NO. 1
3. ALARM 2	ON
4. LINKAGE2	NO. 2
5. ALARM R. TIME	05
6. RETURN	

HOME OPTION: enter the submenu of automatic home function.

AUTO HOME: when this option is set at ON, home position function is opened. This means the PT shall return home position if user has no any action in a period of time. The PT cannot return home position automatically if it is under the patrol state. If no home returning is needed under the stop state, please set this option at OFF.

HOME POS: set home position. HOME POS can be set from preset 1 to preset 63, or preset 65 to preset 128.

DWELL TIME: set the time for home position, which means the PT shall go to home position if no any control occurs within the set time from 1 to 99 minutes.

RETURN: return to the menu one level up.

RETURN: return to the main menu.

HOME OPTION	
1. AUTO HOME	ON
2. HOME POS	01
3. DWELL TIME	05 MIN
4. RETURN	

Program

AUTO PAN START POS: to set the start point of the AutoPan. After entering, move the PT by the joystick. Push CLOSE button to save the current position and return.

AUTO PAN END POS: to set the end point of the AutoPan.

PROGRAM	
1. AUTO PAN START POS	
2. AUTO PAN END POS	
3. RUN AUTO PAN	SLOW
4. SET TITLE	01
5. SET PATROL	01
6. RUN PATROL	01
7. RECORD PATTERN	
8. RUN PATTERN	
9. RETURN	

After entering, move the PT by the joystick. Push CLOSE button to store the current position and return.

RUN AUTO PAN: to run the AutoPan. Please set the start point and the end point first. If the start position and the end position is the same position, the PT shall make 360 °AutoPan. The speed of the AutoPan is divided into six grades: FAST/NORMAL/SLOW/ -FAST/-NORMAL/-SLOW. The first three grades are the AutoPan less than 180 °while the latter three grades are the AutoPan larger than 180 °. The speed can be adjusted by PAN LEFT/PAN RIGHT. Push OPEN button to run and exit the menu. The start point and the end point are set from options 1 and 2 on this menu.

SET TITLE: to edit the titles of preset. Only first 63 presets may have their titles and the preset number can be selected by PAN LEFT/PAN RIGHT. Press OPEN button to enter into the edit state and press CLOSE button to exit the edit state. Operations under the edit state can be seen thereafter.

SET PATROL: to edit patrol data. Select the number of patrol by PAN LEFT/PAN RIGHT. Press OPEN button to enter into the edit state and press CLOSE button to exit the edit state. Operations under the edit state can be seen thereafter.

RUN PATROL: to run patrol function. Select the number of patrol by PAN LEFT/PAN RIGHT. Press OPEN button to run and exit the menu.

RECORD PATTERN: to recode pattern. It can remember PTZ operation for 40 seconds. Complete the edit when 40 seconds are up or push CLOSE button.

RUN PATTERN: To playback pattern. You can also control the joystick to stop running.

RETURN: return to the main menu.

3. Appendix of the Manu

Operation of Patrol under the Edit State

After entering into the edit state, the screen shows as follows:

NO	POS	SP	TM	POS	SP	TM
01	001	01	01	002	01	01
03	003	01	01	004	01	01
05	---	---	---	---	---	---
07	---	---	---	---	---	---
09	---	---	---	---	---	---
11	---	---	---	---	---	---
13	---	---	---	---	---	---
15	---	---	---	---	---	---

NO – serial number of patrol
 POS – number of preset
 SP – leaving speed
 TM – dwelling time

Enter into edit state, display on screen is as follows:
 Edit Area, one line shows data of two point .

SEQ: 01 CLOSE:EXIT

SEQ: 01 – it means current set patrol 1
 CLOE: EXIT – push CLOSE to exit edit state

The top line and the bottom line display prompt message, and the middle area displays information of each locus, **one line shows data of two points**. Move the cursor by PAN LEFT/RIGHT and modify data by TILT UP/DOWN. Press the button down for 1 second to accelerate. Press CLOSE button to exit the edit state and store modification. In above figure, the program stores four patrol points. The settable range of POS is from 1 to 63 or 65 to 128. In case POS is “---”, it’s means the skip this point. The settable range of SP is from 0 to 8 (0 and 1 are same at the highest speed while

grade 8 has the lowest speed). The settable range of TM is from 0 to 99 seconds.

Operation of the Title of Preset under Edit State

After entering into the edit state, the screen show as the drawing. You can find current setup is the preset 1 with the title “NO TITLE”. Move the cursor by PAN LEFT/RIGHT and modify data by TILT UP/DOWN. Press the button down for 1 second to

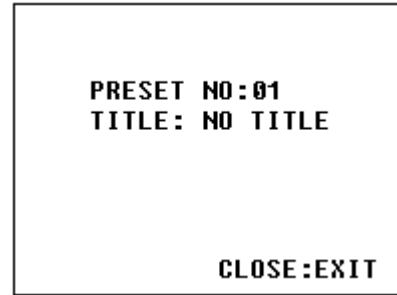

accelerate. Press CLOSE button to exit the edit state and save modification. The title of preset can contain 8 characters such as 0~9, A~Z, +, - and blank. Note: the first letter should be 0~9 or A~Z otherwise it means to delete the title of the presets and it shall only show “NO.XXX” without the title when preset points.

VI Technical Data

1. PAN/TILT

Power supply	AC220V/110V/24V 50/60Hz selectable
Power consumption	70W
Sync system	Internal/External selectable
Preset	128 presets
Patrol	6
Pattern	40s
Alarm	2 channels input
Zoom-rotation Interaction	Control speed auto adjust according to the focus length
Auto flip	NON
Auto pan scan	360° Programmable
Pan speed	100° /s (max)
Pan rotation range	360° continues
Title range	Tilt 90°
Tilt speed	40° /s (max)
Control mode	RS485
Baud Rate	2400/4800/9600/19200 bps
Fan & heater	Fan & heater auto-start
Humidity	10% to 90% RH
Environment temp	-35°C -- +55°C

2. Camera optional data table

Model		18×	23×	26×	27×
		Day/Night switch	Day/Night switch	Day/Night switch	Day/Night switch
Sync mode		Internal/External			Internal
Image Inductor		1/4" Color CCD			
Scanning system		2:1 interlacing	non-interlace	2:1 interlacing	
Resolution		≥480TVL			
Effective Pixels	PAN	752×582(440K)	758×592(450K)	752×582(440K)	795×596(470K)
	NTSC	768×494(380K)	758×504(380K)	768×494(380K)	811×508(410K)
Sensitivity		1Lux / 0.01Lux	0.01Lux	0.01Lux	1Lux / 0.01Lux
IRIS		Manual/Auto			
FOCUS		Manual/Auto			
ZOOM RATE		18× optical	23× optical	26× optical	27× optical
		12× digital	12× digital	12× digital	10× digital
		f=4.1 to 73.8 mm	f=3.6 to 82.8 mm	f=3.5 to 91 mm	f=3.6 to 98 mm
Angel of view		Wide: 48°	Wide: 54°	Wide: 54.2°	
		TELE: 2.8°	TELE: 2.5°	TELE: 2.2°	
B.L compensation		ON/OFF			
White balance		Manual/Auto			
Gain Control		Manual/Auto			
S/N		≥50dB			
Video output		VBS: 1.0Vp-p/75Ω			