

Intelligent IR HD-SDI High Speed PTZ Manual Operation

VER:2.5.2

Please read the manual carefully before using the product.

I. Notes for Attention

1. Read the manual carefully before installing the product.
2. There are two input ways of power supply: DC12V. Detailed connections refer to the description files.
3. There are sophisticated optical and electronic components inside the product. Avoid incorrect operation methods such as heavy pressing or strong vibration during the course of transportation, store and installation otherwise the product could be damaged.
4. Please do not dismount components inside the product to avoid occurrence of trouble. There is no part inside the product, which needs repair by customer himself.
5. Observe all electric safety standards in application and adopt special power supply attached the product. RS-485 control signal and video signal should be kept enough distance with the high voltage devices and cables during the course of transmission, and take protection measures such as anti-lightning and surging etc. if necessary.
6. Do not apply the product under the state exceeding limited temperature, humidity or specifications of power supply.
7. Do not aim the camera at the sun or very bright object, aim or monitor bright and still object for a long time whether the power supply of the camera is switched on or off.
8. Clean out dirt with special lens tissue if dust is stuck on the lens.

II. Description of Functions

This product is a high-tech monitor and controller which incorporates high definition color camera, universal variable pan/tilt, infrared lighting, multi-functional decoder, character superimposing, alarm input/output into a whole, reduces interconnections to a great extent among parts in the system and rises up the reliability of the system. In addition it has advantages of easy installation and maintenance, beautiful appearance, lightweight and flexible, simple operation etc.

1. Integrated Multi-Protocol Decoder

- a. The built-in decoder integrates 9 kinds of communication protocols in maximum. The baud rate of communication is adjustable. It has strong universality and is compatible with multiple common systems only by simple setting on the dip-switch.
- b. RS485 serial control: addresses of the pan/tilt 1 – 1023.

2. Integrated Panoramic Pan/Tilt

- a. 360 continuously rotation for pan range, manual control speed from 0.9rad/s-60rad/s ,Preset speed at 100 %S; Tilt range from-90 °~90 °; manual speed at 40rad/s, preset speed at 60 %S.
- b. Smooth running at low speed with super lower noise. Images have no fluttering.
- c. Panoramic monitor without black spot and the positioning accuracy can reach $\pm 0.1^\circ$

3. High Degree of Intelligence

- a. Preset memory has as much as 256 positions. Data are kept in memory even power is failure.

-
- b. Horizontal scan between two positions are supported. Scan speed can be altered and direction of pan can be selected freely. The pan/tilt can make scan larger or smaller than 180 °between any two positions with adjustable speed.
 - c. 6 groups cruising tracks. Each cruising track with 16 presets positions,speed and staying time of each preset position could be adjusted.
 - d. Long focus speed-limited function. The pan/tilt can adjust automatically the manual control speed depending on the focal length of the camera. The larger the magnification times, the slower the manual control speed thus to ensure searching the target rapidly and accurately.
 - e. Integrated multiple protocols. A lot of communication protocols are integrated inside the pan/tilt with selectable baud rates from 2400 bps to 19200 bps.

4. Camera Function: Refer to Camera

- a. Control Mode of Focal Length: the user can manually adjust the focal length of the camera.
- b. Control of Magnification: the user can “pull up” or “push away” the lens
- c. Backlight Compensation: in case the lit object has dark background and couldn't be displayed clearly, the user can switch on the backlight compensation .
- d. White Balance: in case images have distorted color on the screen, the user can set various kinds of modes by orders. There are six modes available for selection: ① indoor mode ② outdoor mode ③ trigger mode ④ auto tracking white balance ⑤ manual white balance ⑥ automatic mode.
- e. AE Mode: manual/automatic setup.
- f. Setup of Low Illumination: normally the camera operates under normal condition. In case when ambient illumination is lower than 1 LUX, the camera can automatically switch into zero illumination state . You can also make the camera under the zero illumination state manually.
- g. Other function: refer to different camera by using system menu to control.

5. Infrared System

- a. The infrared system is normally under automatic control state. The infrared lamp shall act followed by open/close of the low illumination of the camera;
- b. The open/close state of the infrared lamp can be changed by the menu manually;
- c. The default option on the menu of the infrared lamp is OFF. Normally the system detects external illumination and opens/closes the infrared lamp automatically. If the user changes the option of the infrared lamp into ON, the infrared system is changed into the manual control; if changing back into the automatic control, the user should set the option on the menu of the infrared at OFF.

III、Fast Commands

Preset position	Set Presets	CALL Presets	Notes
11	Fill light OFF	Fill light ON	Notes: Functions decided by using camera models
12	D-ZOOM OFF	D-ZOOM ON	
13	Camera Screen OFF	Camera Screen ON	
21	Wiper single start	Fill light auto mode	
22	BLC OFF	BLC ON	
23	WDR OFF	WDR ON	
31	Home position OFF	Home position ON	
32	Record patterns	Play patterns	
51	Wiper multiple functions ON	Wiper multiple functions OFF	
52	Defrost function ON	Defrost function OFF	
53	Resolution 720P50	Resolution 1080I50	
54	Resolution 720P60	Resolution 1080P30	
55	Resolution 720P30	Resolution 1080I60	
56	Resolution 720P25	Resolution 1080P25	
91	Start cruising		
92	Set horizontal line scan left limit		
93	Set horizontal line scan right limit		
97	Run horizontal line scan		

IV、 Setup of the Intelligence Full-Dome Pan/Tilt

Before installing the product, first of all confirm the communication protocol and the baud rate of the main machine in the system, then set the dip-switch SW2 of the pan/tilt to be identical with that of the system, set the address of the pan/tilt on SW1 and the type of the communication protocol and the baud rate on SW2.



(Figure 1)

1. Terminal Resistor:

The jumper JP1 is the option switch of 120 Ω terminal resistor of the bus RS485. When it is at 2—3 state, 120 Ω terminal resistor is opened and no bus 485 is connected; when it is at 1—2 state, 120 Ω terminal resistor is connected in parallel with the bus 485. In the bus RS485 system, there is only one pan/tilt, which has the terminal resistor to be connected in the circuit and other pan/tilts whose terminal resistors are opened so as to increase the reliability of the system. Generally, the terminal resistor of the pan/tilt at the farthest end from the control circuit is connected and all terminal resistors of other devices are opened.

2. Power supply panel for the PTZ:

Input voltage is DC10.8-18V, $I_{in} \geq 4A$;

3. Dip-Switch of Address:

Dome Address	States of Dip-Switch									
	DIP-1	DIP-2	DIP-3	DIP-4	DIP-5	DIP-6	DIP-7	DIP-8	DIP-9	DIP-10
1	ON	OFF	OFF	OFF	OFF	OFF	OFF	OFF	OFF	OFF
2	OFF	ON	OFF	OFF	OFF	OFF	OFF	OFF	OFF	OFF
3	ON	ON	OFF	OFF	OFF	OFF	OFF	OFF	OFF	OFF
4	OFF	OFF	ON	OFF	OFF	OFF	OFF	OFF	OFF	OFF
5	ON	OFF	ON	OFF	OFF	OFF	OFF	OFF	OFF	OFF
6	OFF	ON	ON	OFF	OFF	OFF	OFF	OFF	OFF	OFF
7	ON	ON	ON	OFF	OFF	OFF	OFF	OFF	OFF	OFF
8	OFF	OFF	OFF	ON	OFF	OFF	OFF	OFF	OFF	OFF
9	ON	OFF	OFF	ON	OFF	OFF	OFF	OFF	OFF	OFF
10	OFF	ON	OFF	ON	OFF	OFF	OFF	OFF	OFF	OFF
11	ON	ON	OFF	ON	OFF	OFF	OFF	OFF	OFF	OFF
12	OFF	OFF	ON	ON	OFF	OFF	OFF	OFF	OFF	OFF
13	ON	OFF	ON	ON	OFF	OFF	OFF	OFF	OFF	OFF
14	OFF	ON	ON	ON	OFF	OFF	OFF	OFF	OFF	OFF
15	ON	ON	ON	ON	OFF	OFF	OFF	OFF	OFF	OFF
16	OFF	OFF	OFF	OFF	ON	OFF	OFF	OFF	OFF	OFF
17	ON	OFF	OFF	OFF	ON	OFF	OFF	OFF	OFF	OFF
18	OFF	ON	OFF	OFF	ON	OFF	OFF	OFF	OFF	OFF
...	...									
1023	ON	ON	ON	ON	ON	ON	ON	ON	ON	ON

SW1 is used to set the addresses of the pan/tilt which has the range from 1 to 1023. From DIP-10 to DIP-1 it corresponds to a binary number with 10 bits in which the highest bit is DIP-10 and the lowest bit is DIP-1. The state ON for each bit means 1 while the state OFF means 0. The encodes of some addresses are as follows:

For example:

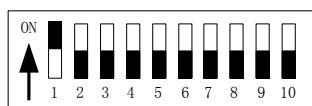

Speed Dome Address=1

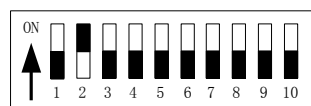

Speed Dome Address=2

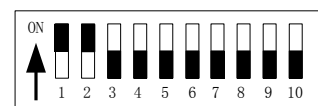

Speed Dome Address=3

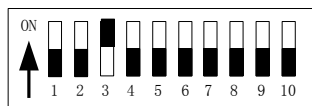

Speed Dome Address=4

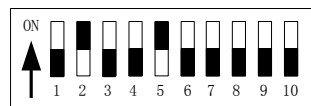

Speed Dome Address=18



Speed Dome Address=1023

- The address of the dome camera is set according to the binary coding system in which ON means "1" and OFF means "0".
- The coded addresses shown above are only from 1 to 18 and those from 19 to 1023 are and so forth.
- Setup of the protocol: the protocol is set up by the first four bits of SW2 and the baud rate is set up by the later two bits. Please refer to the following table and set the protocol and the baud rate to be identical with that of the main machine.

4. Selection of the Protocol and the Default Baud Rate:

SW2 is used to set the communication protocol and the baud rate used by the pan/tilt. Bits from DIP-4 to DIP-1 of the SW2 are used to select the protocol and 9 different protocols can be selected in maximum. The encoded table of the protocol selected by the pan/tilt is as follows:

Type or Protocol	Selection of Communication Protocol				Normal Baud Rate	
	DIP-1	DIP-2	DIP-3	DIP-4	DIP-5	DIP-6
B01	ON	OFF	OFF	OFF	OFF	ON
Santachi	OFF	ON	OFF	OFF	OFF	ON
PELCO-D	ON	ON	OFF	OFF	OFF	OFF
PELCO-P/4800	OFF	OFF	ON	OFF	ON	OFF
PELCO-P/9600					OFF	ON
Longcomity	OFF	ON	ON	OFF	OFF	ON
HUNDA600	ON	ON	ON	OFF	OFF	ON
KALATEL	ON	ON	OFF	ON	ON	OFF
VCL	OFF	OFF	ON	ON	OFF	ON
ALEC	OFF	ON	ON	ON	OFF	ON

5. Setup of the Baud Rate of Communication of the Pan/Tilt (later 2 bits of SW2)

Position of Dip-Switch Baud Rate of Communication	1	2	3	4	5	6
	2400 bps					OFF
4800 bps					ON	OFF
9600 bps					OFF	ON
19200 bps					ON	ON

6. Description of the Terminals

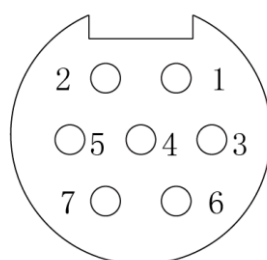

A. 7-Core Input Terminal

7. Description of 7-Core Terminal:

1.DC12V:Red		2.GND:Black
3.R-(communication-):Yellow	4.Null	5.R+(communication+):Orange
6.Null	7.Null	

V. Installation of the Product

5.1 Drawing of the Sizes of the Product (Unit:mm)

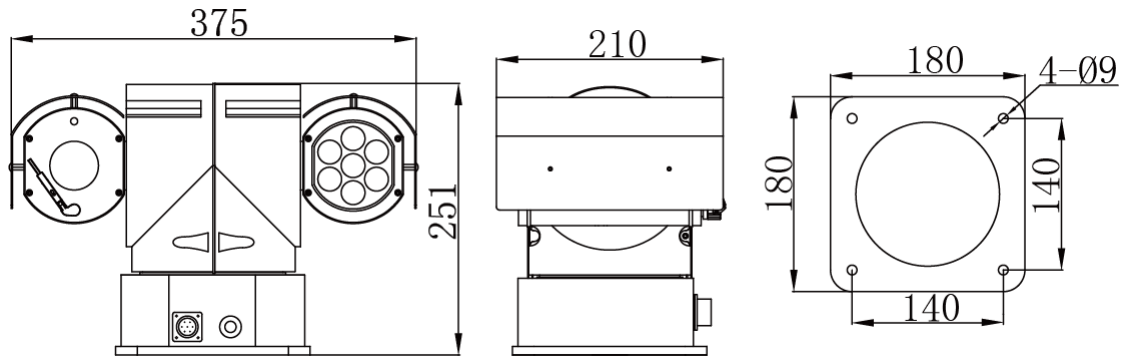

Outline Sizes of the Pan/Tilt

5.2 Installation Style of the Product

A. Installation Style of Plain Base

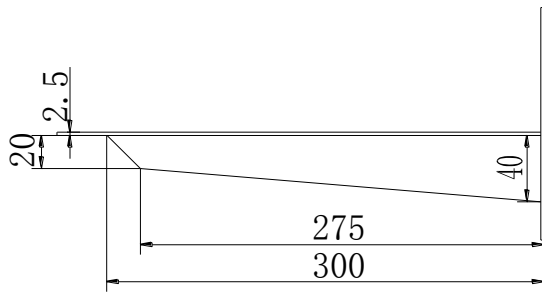

Drawing of Sizes of the Side

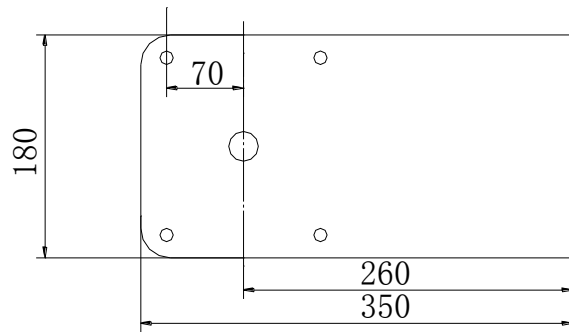

Drawing of Sizes of the Bottom

B. Vehicle -Carried

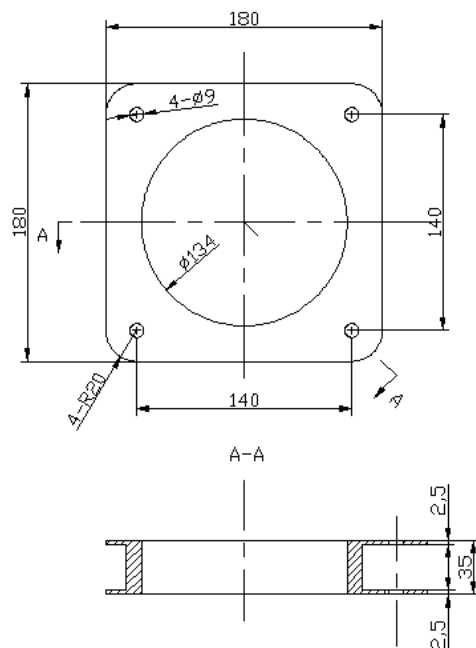

Sizes of the Shock Absorber

5.3 Installation Procedures of the Product

1. Remove the bottom plate of the pan/tilt;
2. Set the corresponding information in accordance with the schematic drawing of the dip-switch of addresses, protocols and baud rates;
3. Install the bottom plate of the pan/tilt and take care of the tightness of waterproof seal ring;
4. If vehicle-carried pan/tilt is used, first of all fix the chock absorber on the bottom of the pan/tilt then fix the whole pan/tilt;

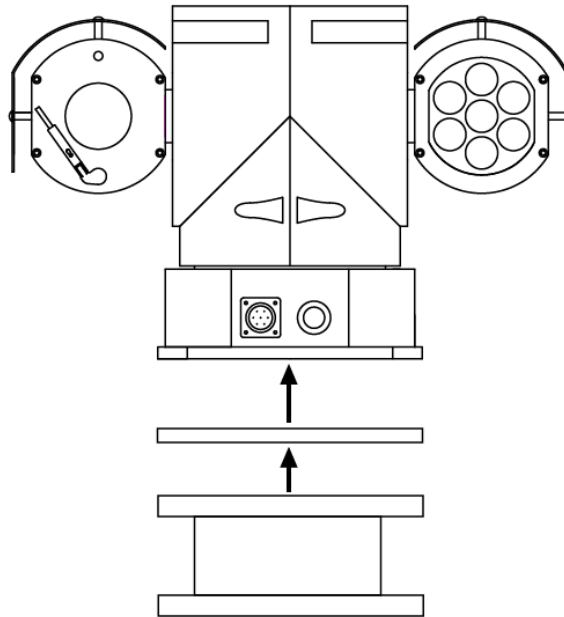

5. If the plain base is used, fix the pan/tilt onto the fixation hole of the pan/tilt;
6. Connect the output wires of the socket according to relative colors on the schematic drawing and do not make wrong connections.

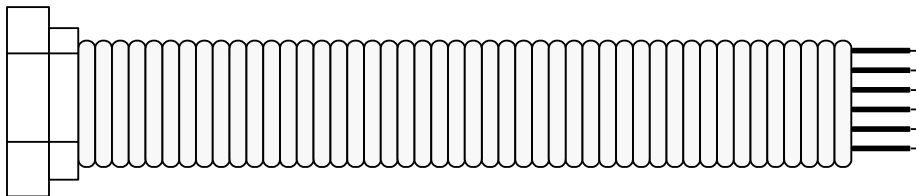

Attention: Descriptions of wires

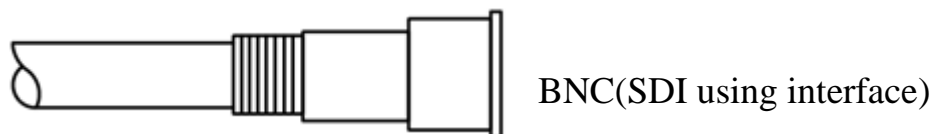
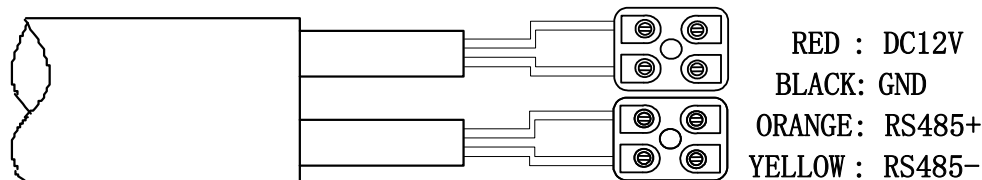

Attention: the input of power supply couldn't be selected and should be connected as per actual applied style.

VI、 Main Technical Index		
Specifications	Power Supply (Option)	DC11-18V $I_{in} \geq 4A$
	Power Consumption	50VA
	Weight	7Kg
	Installation Style	Plain Base Installation
	Relative Humidity	10-90%
	Operation Temperature	-35°C~55°C
	Waterproof Class	IP66
	Iris & Zoom	Automatic/Manual
Basic Functions of Pam/Tilt	Pan range	100° /S max
	Tilt range	60° /S max
	Preset Position	256 positions in maximum
	Patrol Function	Support
	Scanning Speed	0.5~30° /s
Infrared Lamp	Infrared Illuminator	High Brightness LED X 7
	Wavelength	850nm
	Project Distance	120m
	Power Consumption	10W
	Control of Infrared Lamp	Auto/Manual control on menu
	Service Life of Infrared Lamp	Over 20000 hours

VII. Normal Troubles and Remedies

Troubles	Possible Causes	Remedies
No action and images after switching on	Power supply damaged of insufficient electric power	Replace
	Wrong connection of power supply wires	Make correction
	Engineering circuits failed	Remove
Abnormal self-inspection, images with humming of motor	Mechanic trouble	Repair
	Pan/tilt may be inclining	Re-fix
	Insufficient electric power	Replace with qualified power supply
Normal self-inspection, no images	Wrong connection of VF circuit	Make correction
	Bad contact of VF circuit	Remove
	Camera damaged	Replace
Successful self-inspection without control	Wrong connection of control signal wires	Make correction
	Mismatched address	Re-select
	Mismatched protocol	Make mismatch of protocol and controller and restart
Unstable images	Bad contact of VF circuit	Remove
	Insufficient electric power	Replace
Dome pan/tilt out of control	Abnormal self-inspection	Restart
	Bad contact of control circuit	Remove
	Operation of main machine has problem	Restart the main machine
	Much load or communication distance too far	1. Connect 120Ω resistor of the farthest dome pan/tilt from the controller and disconnect all other resistors; 2. Add coding divider
Auto/Manual of infrared lamp ineffective	Infrared lamp may be damaged	Rework

Some common troubles and their causes and remedies are listed above for your reference. Should you meet other special problem, you can contact with the dealer directly for technical support.